

APPLICATIONS FOR AQUABAR® “B” UNDERLAYMENT MEMBRANE

THE DETAILS SHOWN HERE REFER TO GENERALLY ACCEPTED
WOOD FLOOR INSTALLATION PRACTICES

Aquabar “B” is the most effective moisture vapor retarder for use under wood flooring. It is a cleaner and easier handling product than roofing felt and poly film. Aquabar “B” slows moisture migration and is a superior vapor retarder. **It is not a vapor barrier or waterproof membrane.** Aquabar “B” meets IBC® and IRC® code requirements as a Class II membrane.

HARDWOOD FLOORS

Under wood floors, **Aquabar “B”** serves as a moisture vapor retarder, reducing or preventing moisture migration from below the floor system, along the wood flooring to acclimate gradually. As a semi-permeable material, **Aquabar “B”** is also much less likely than poly film, coated paper or other materials to trap moisture condensation between it and the sub-floor. Installed under wood floors as a “slip sheet”, **Aquabar “B”** helps keep down dust and reduces squeaks. Aquabar “B” may be used in applications over a wood sub-floor, on joists or concrete.

This application guide provides examples of typical wood flooring installations using **Aquabar “B”**. The descriptions are brief and do not cover all circumstances that the installer may encounter during installation. It is the responsibility of the installer to obtain, read and follow the flooring manufacturer’s instructions, NWFA guidelines and all applicable building codes for proper installation of wood flooring.

For best results when installing, we suggest using a NWFA Certified Professional.

JOB SITE CONDITIONS

- Building must be completely enclosed
- Site drainage directs water away from foundation
- All other interior work should be completed
- Interior environmental conditions must be at occupied levels
- Basements and crawl spaces must be dry
- Acclimate flooring per manufacturer’s recommendation

SUB-FLOOR PREPARATION

- All surface debris and protrusions must be removed
- Check sub-floor for squeaks and repair
- Sweep and vacuum prior to filling or repairing voids
- Fill voids and level high spots, sweep again

WOOD SUB-FLOORS – NAILED

Always read and follow the floor manufacturer’s installation instructions. For installations over wood joist construction be sure, if above a crawl space, the ground is covered by **Moistop Ultra®** or a vapor retarder with a perm rating of ≤ 0.04 , and crawl space is properly ventilated. Cut **Aquabar “B”** to length and position over

sub-floor as needed for proper coverage. Overlap all seams a minimum of 4 inches. **Aquabar “B”** may be loose-laid or stapled over sub-floor. Once **Aquabar “B”** is installed, snap chalk lines to desired layout.

CONCRETE SUB-FLOORS – FLOATED & NAILED

For on-grade slabs, the following conditions must be met:

- An underslab vapor retarder has been properly installed, such as Fortifiber’s **Moistop Ultra** family of products.
- The slab is thoroughly dry before installation of wood flooring. Generally, slabs must be 60 days old. Test for moisture, following flooring manufacturer’s recommendations.
- To be certain normal slab moisture does not reach the wood flooring, install a vapor retarder with a perm rating of ≤ 0.04 , such as Fortifiber’s **Moistop Ultra**, over the slab.

Then follow wood floor manufacturer’s recommendation for placement of plywood. Cut and install **Aquabar “B”** over plywood as above.

CONCRETE SUB-FLOORS – SCREED SYSTEM

Install flat, dry, preservative treated 2x4s, cut 18-24” long, laid flat at right angles to finished floor, spaced 12” o.c. and embed in adhesive. Then lay a vapor retarder with a perm rating of ≤ 0.04 over screeds, install plywood and cover with **Aquabar “B”** as above.

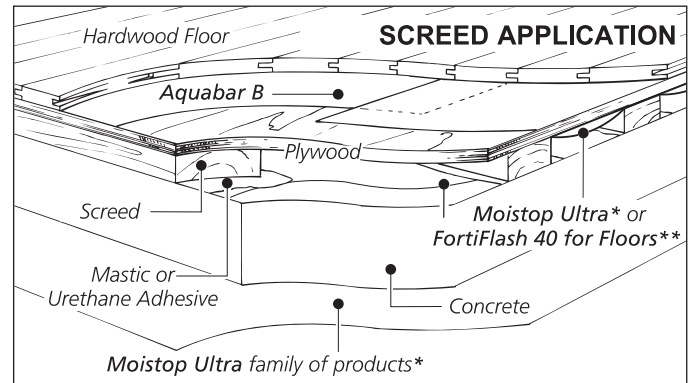
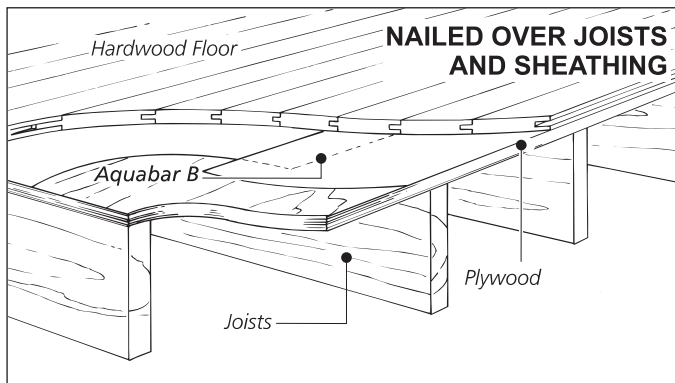
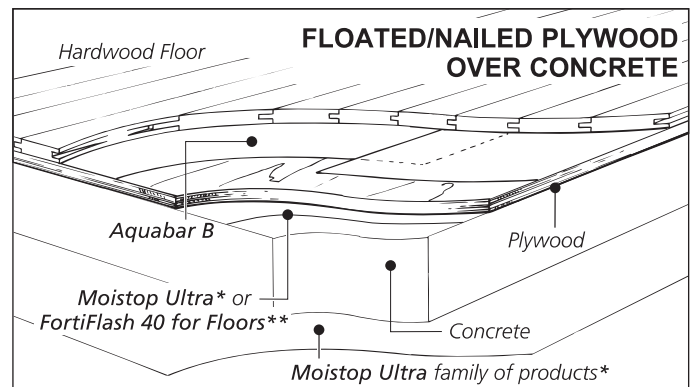

Passed CA01350
Indoor Air Quality
Emission Requirements

nwfa
National Wood
Flooring Association
MEMBER

NWFA
accepted product
NATIONAL WOOD FLOORING ASSOCIATION

*The **Moistop Ultra®** family of Class I vapor retarders are critical for Wood and Tile floors placed over concrete slabs.

** See **FortiFlash® 40 for Floors** installation guide or warranty for details.

CONTINUED ON BACK...